

Controllers

Basic range:

4-way controller basic, PLE-30-040

- Direct control (400-415V-3ph-50Hz)
- Pre selection facility for all units
- Output: 1 x Harting 16p connector for hoist connection
- Input power: 100 cm power cable with 1 x CEE 32A-5p plug with phase reverse
- Short circuit protection for power and control
- Emergency stop button
- 19"4U rack housing

8-way controller basic, PLE-30-080

- Direct control (400-415V-3ph-50Hz)
- Pre selection facility for all units
- Output: 2 x Harting 16p connector for hoist connection
- Input power: 100 cm power cable with 1 x CEE 32A-5p plug with phase reverse
- Short circuit protection for power and control
- Emergency stop button
- 19"4U rack housing

Modular range:

Controllers based on a master/slave system, for BGV D8 and BGV-D8+ qualified hoists. The master controller is a 4-way controller, which complies with all regulations, following the IEC and EMC as well as the strict BGV. With this type of controller Prolyte is not only ahead of regulations, but has a vanguard position compared to other control manufacturers as well.

Each master can control up to 3 slave controllers, thereby creating a 16-channel controller. The individual masters can be interconnected to serve a system up to 64 channels. All pre-selected hoists will be activated by one single run button. If the protection system of one of each hoist is activated, this will automatically deactivate the complete control system. A feature, which brings a high factor of safety into your control system and your truss structure.



4-way controller "master", PLE-30-041

- Direct control (400-415V-3ph-50Hz)
- Pre selection facility for all units
- Output: 1 x Harting 16p connector for hoist connection
- Input power: 100 cm power cable with 1 x CEE 32A-5p plug with phase reverse
- Short circuit protection for power and control
- Phase reverse or failure detection
- Emergency stop button
- Road proof steel 19"4U rack housing
- Master/slave link connection
- Adjustable thermal circuit breaker per hoist with reset function

4-way controller "slave", PLE-30-042

- Direct control (400-415V-3ph-50Hz)
- Pre selection facility for all units
- Output: 1 x Harting 16p connector for hoist connection
- Input power: 100 cm power cable with 1 x CEE 32A-5p plug with phase reverse
- Road proof steel 19"4U rack housing
- Adjustable thermal circuit breaker per hoist with reset function

Remote control is available as an option for the modular range controllers.

Service points

DECIMA SRL
Italy
phone : +39-0498701655
website: www.decimaitalia.com

ENTTECH S.A.
Greece
phone : +30-2108257070
website: www.enttech.gr

ERCA / EVDV
Belgium
phone : +32-38860300
website: www.evdv.com

FISCHER Art of Light and Sound GmbH
Germany
phone : +49-421 6260233
website: www.fischer-online.de

FRESNEL S.A.
Spain
phone : +34-932107351
website: www.strong.es

HEDCOM OY AB
Finland
phone : +358-9-6828 4600
website: www.hedcom.fi

IMPACT
France
phone : +33-149752424
website: www.impact-even.com

PRO 1
Latvia, Lithuania, Estonia
phone : +371-7228113
website: www.pro1.lv

RST DISTRIBUTION GmbH
Germany
phone : +49-2331 691500
website: www.rstdistribution.de

STAGE RIGGERS INC
Philippines
phone : +632-5314661
website: www.stageriggers-ph.com



Industriepark 9, 9351 PA Leek
The Netherlands
phone : +31 (0)594 85 15 15
fax : +31 (0)594 85 15 16
e-mail : info@prolyte.com
website: www.prolyft.com

The Prolyte Performance hoist

Taking it to a new level



"Finally a hoist that combines the best features in the market."



Taking it to a new level

Prolyft

Prolyte has a renowned reputation for high quality products. It is from this background that Prolyte has decided to use their insight in market demands and product expertise to redefine the concept of rigging. Similar to other Prolyte products the concept is simple: translate user demands into a high quality and affordable product. The outcome is a sturdy, road proof line of electrical chain hoists with user-friendly features.

A worldwide network of trained and competent service points sells the Prolyft Performance hoist. Apart from a regular stock, the service points can provide spare parts and repair and maintenance service. So wherever you are based, you can be sure of the best possible service.

The Prolyft Performance hoist



500 / 1000 Kg version

Prolyft Performance Strong points

- Lightweight; compact aluminium housing
- Silent; five pocket load wheel for smooth operation
- Versatile; 136- 2000 kg lifting capacity, lifting speeds from 2 to 10 m/min.
- Strong; road proof housing and features
- User friendly; modified to the specifications of a team of qualified riggers
- High Quality; Complies to all applicable European and American safety standards

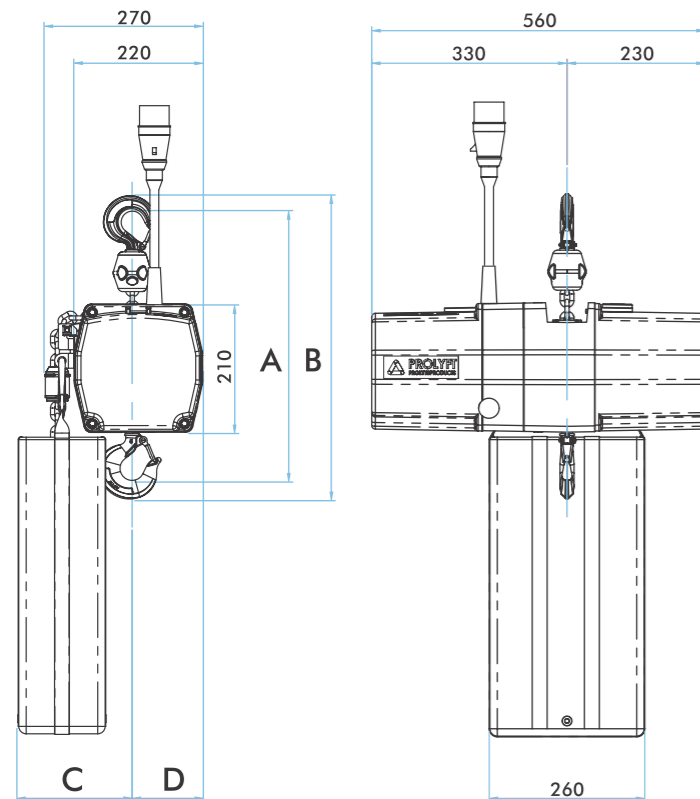

A : 500 / 1000 Kg MIN. 411 mm - 2000Kg MIN. 478 mm
 B : 500 / 1000 Kg MIN. 469 mm - 2000Kg MIN. 542 mm
 C : 500 / 1000 Kg 196 mm - 2000Kg 218 mm
 D : 500 / 1000 Kg 121 mm - 2000Kg 99 mm

Unique Lifetime Warranty system:

Prolyte offers an unique Lifetime Warranty system. Each hoist is equipped with an electronic tag, which enables the owner to keep track of the hoists' history in an easily accessible database. If the hoist is tested at regular intervals at one of the Prolyft service points, Lifetime warranty is guaranteed.

Standard features:

- Direct control
- CEE 16A-4p plug and cable with strain relief
- Multiple voltage motor
- Chain bag for max. 30m. chain
- Jam free chain guide
- Internal, sealed clutch, to be adjusted by authorised personnel only
- Free rotating hand grips
- Standard swivel hook on upper and lower chain
- Zinc plated load chain
- Silent oil based gearbox

Options:

- Low voltage control (115/48V)
- Single phase version
- Double brake
- Limit switches
- Build in encoder
- BGV C1 version



250 Kg version

Technical specifications Prolyft Performance hoist PLE series

	PLE-10-001	PLE-11-001	PLE-12-001	PLE-13-001
Load capacity	250kg	500kg	1000kg	2000kg
lifting speed 50Hz standard m/min	4	4	4	2
Operating voltage	400v-3P-50Hz/ 460v-3p-60Hz	400v-3P-50Hz/ 460v-3p-60Hz	400v-3P-50Hz/ 460v-3p-60Hz	400v-3P-50Hz/ 460v-3p-60Hz
Single phase operation	n/a	optional	optional	optional
Protection class	IP 54*	IP 54*	IP 54*	IP 54*
Motor power at 50Hz	0,16kw	0,75kw	0,75kw	0,75kw
Power consumption at operation	0,7amp	1,9amp	1,9amp	1,9amp
FEM Duty factor	40%	40%	40%	40%
Starts per hour	300	300	300	300
Noise level	55db	68db	68db	68db
Load wheel	10 pocket	5 pocket	5 pocket	5 pocket
Load chain DIN 5684	3,9 x 11,9	7,1 x 20,5mm	7,1 x 20,5mm	7,1 x 20,5mm
Falls of chain	1	1	1	2
Weight of chain per meter lift	0,34kg	1,1kg	1,1kg	2,2kg
Weight of body	11kg	34kg	34kg	37kg
Type of control	direct	direct	direct	direct
Type of connector	CEE 16A-4p	CEE 16A-4p	CEE 16A-4p	CEE 16A-4p
Low voltage control	optional 48v/ 115v	optional 115v	optional 115v	optional 115v
Suspension with swivelhook	n/a	standard	standard	standard

* IP 55 available as option

Plug & run hoists:

Apart from the regular 3 phase hoists, Prolyte also offers a series of unique single phase, 220V hoists in the range from 113-500 kg lifting capacity and lifting speeds from 1,5 to 4 m/min.

Controllers

Multi channel controllers

The Prolyft controllers have been developed specially for the control of the PLE series chain hoists. The controllers are available in standard 4 or 8 channel units in 19" rack housing.

The controllers allow you to control the hoists individually or simultaneously with one single button. For larger applications the controllers can be interconnected to serve a system up to 64 channels.

All pre-selected hoists are activated by one single run button.

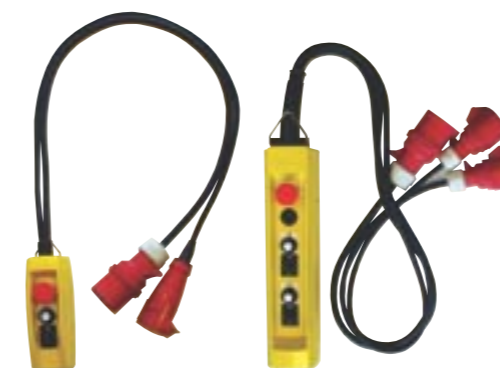

1-way control, PLE-30-010, incl. high voltage contactors and emergency stop button, 1 x CEE 32A-5p plug and power cable and 2 x CEE 16A-4p plug and power cable.

2-way control, PLE-30-020, incl. high voltage contactors and emergency stop button, 1 x CEE 32A-5p plug and power cable and 1 x CEE 16A-4p plug and power cable.